



NAPCO[®]
 NAPCO SECURITY SYSTEMS,
 INC.
 333 BAYVIEW AVENUE
 AMITYVILLE, NEW YORK
 11701

INSTALLATION INSTRUCTIONS

**GEM-SMK
 Supervised
 Digital Smoke Detector**

© Napco 1998

WI750A 12/96

Description. The GEM-SMK is a high-quality photoelectric smoke detector with built-in supervised digitally-coded radio transmitter. It is compatible with Napco's GEM-RECV Series supervised security receivers that monitor alarms, restores, low battery and status.

The GEM-SMK sounds a local alarm as soon as smoke is detected and the transmitter will send an alarm signal to the supervised receiver. The alarm signal will be repeated every 10 seconds thereafter as long as smoke is still present. A restore report will be sent when the smoke-detection cham-

ber clears. Supervisory status reports are sent from the GEM-SMK every hour.

Coding switches are not required or used in the GEM-SMK. Each transmitter is assigned a unique identification code number at the factory.

The smoke detector and transmitter are powered by two 9-volt alkaline batteries (supplied) which can power the unit for up to two years. If the battery voltage drops below normal, a low-battery report will be sent to the receiver with any status or alarm transmission. If a low-battery condition is indicated, replace *both* batteries. **Note:** Temperature and humidity extremes may reduce the life of the battery.

Step 1. Remove the mounting plate. Remove the GEM-SMK mounting plate by turning the plate counterclockwise and pulling it up.

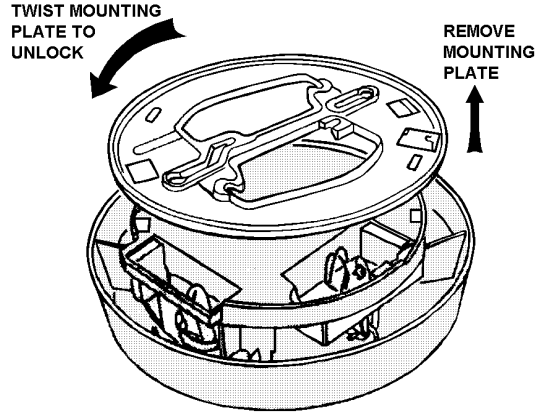

Step 2. Identify components. Examine the GEM-SMK to identify the component locations.

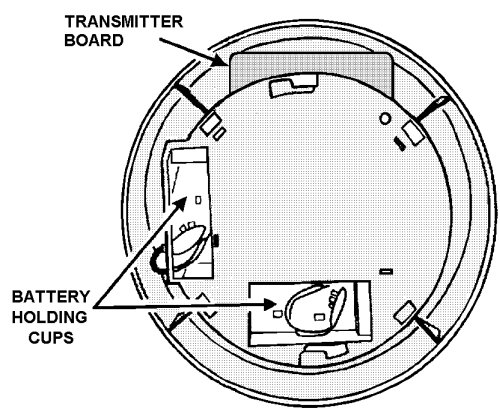

Step 3. Install batteries. Connect the two 9-volt alkaline batteries and place them into the battery holding clips.

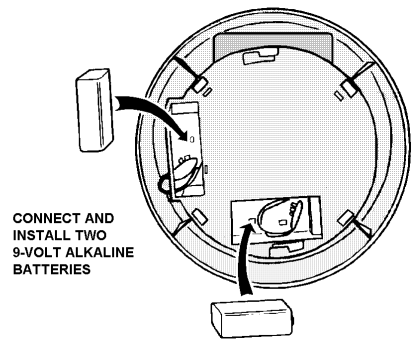

Step 4. Pick smoke-detector location. Referring to the NFPA standard on page 3, select a good location to mount the GEM-SMK. *Mounting the GEM-SMK on foil-backed wallpaper or on metal single-gang electrical box is not recommended because the radio range will be reduced.*

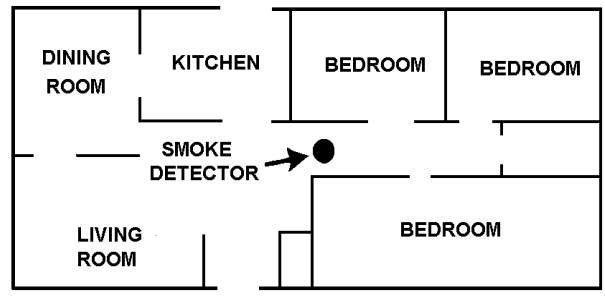

Step 5. Install mounting plate. Use the two screws and anchors provided to attach the mounting plate to the wall or ceiling. Alternatively, the mounting plate may be attached to a *plastic* single-gang electrical outlet box.

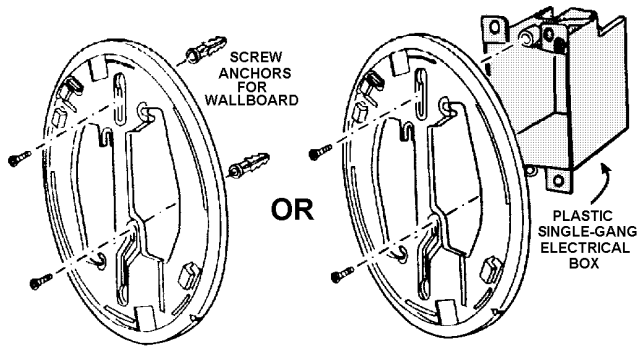

Step 6. Map the GEM-SMK Transmitter. Referring to the instructions for the panel and keypad in use, enter the following:

- the zone to which the transmitter will be mapped;
- the 6-digit identification number/1-digit checksum number printed on the transmitter (include all numbers and/or letters and leading zeros, if any); and
- the transmitter point number ("1").

Step 7. Attach the GEM-SMK to mounting plate. Match up alignment tabs on detector and plate. Turn detector clockwise until it locks into place.

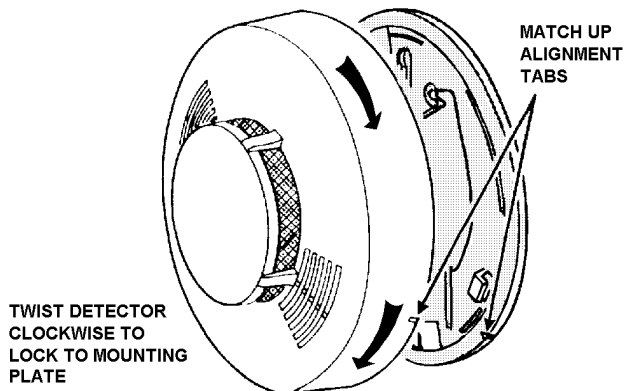

Step 8. Test system with unit mounted. If the system is monitored, notify central station of impending test. Press and hold the test button. Keep the button depressed for 30 seconds after the local alarm sounds. Verify that the GEM-SMK triggers the correct zone on the control panel and that the correct report is sent to the central station.

PRESS AND HOLD
DETECTOR TEST
BUTTON.

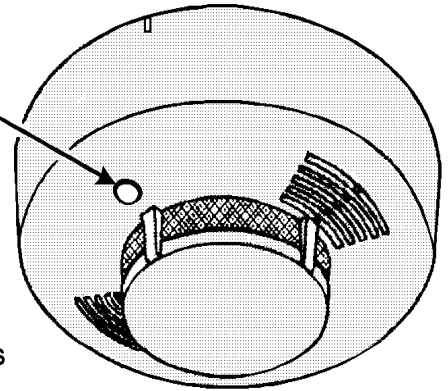

HOLD BUTTON FOR
AT LEAST 30 SECONDS
AFTER LOCAL ALARM
SOUNDS TO SEND AN
ALARM TRANSMISSION.

Maintenance. To clean the smoke detector, vacuum the outside of the unit at least once a year (preferably every six months) using a soft brush attachment. Do not attempt to

NFPA STANDARD FOR SMOKE-DETECTOR LOCATION

The GEM-SMK should be installed in accordance with the National Fire Protection Association (NFPA) Standard 72, which is summarized below.

Smoke detectors shall be installed outside of each separate area in the immediate vicinity of the bedrooms and on each additional story of the family living unit including basements and excluding crawl spaces and unfinished attics. This represents the minimum number of detectors required. It is recommended that the householder consider the use of additional smoke or heat detectors for increased protection for those areas separated by a door from areas protected by the required smoke detectors. The recommended additional areas are: living room, dining room, bedroom(s), kitchen, attic (finished or unfinished), furnace room, utility room, basement, integral or attached garage and hallways. However, the use of additional detectors remains the option of the householder.

For family living units with one or more split levels (i.e., adjacent levels with less than one full story separation between levels), a smoke detector required as above shall suffice for an adjacent lower level, including basements.

Exception: Where there is an intervening door between one level and the adjacent lower level, a smoke detector shall be installed on the lower level.

® Ceiling-mounted smoke alarms should be located in the center of the room or hall, or not less than 4 inches from any wall. When the detector is mounted on a wall, the top of the detector should be 4 to 12 inches from the ceiling.

® Do not install smoke alarms where normal ambient temperatures are above 100°F (37.8°C), or below 40°F (4°C). Also, do not locate alarm in front of air conditioners, heating registers, or other locations where normal air circulation will keep smoke from entering the detector.

FIRE PREVENTION AND ESCAPE

The purpose of an early warning smoke alarm is to detect the presence of fire in its early stages, and sound an alarm giving the occupants more time to exit the premise before the smoke reaches a dangerous concentration level.

Fires start even with the best of housekeeping and fire-prevention procedures. Fire is an unexpected event. Early warning detection alerts occupants in time to act.

KNOW FIRE HAZARDS. No detection device can protect life in all situations. Therefore, safeguards should be taken to avoid such potentially dangerous situations as smoking in bed, leaving children home alone, cleaning with flammable liquids such as gasoline.

the best fire protection is minimizing fire hazards through proper

storage of materials and general good housekeeping techniques. A cluttered basement, attic, or other storage area is an open invitation to fire.

Careless use of combustible materials and electrical appliances, or overloading of electrical outlets are other prime causes in starting fires.

It is most important that explosive and/or fast-burning materials be eliminated from the home if at all possible.

Even after proper precautions have been taken, fires can start. Be prepared.

IN CASE OF FIRE. Leave immediately. Don't stop to pack or search for valuables. In heavy smoke, hold your breath and stay low -- crawl if necessary. The clearest air is usually at the floor.

If you have to go through a closed door, carefully feel the door and door knob to see if undue heat is present. If they seem relatively cool, brace your foot against the bottom of the door with your hip against the door and one hand against the top edge. Open it slightly. If a rush of hot air is felt, slam the door quickly and latch it. Unvented fire tends to build up considerable pressure. Be sure all the household realizes and understands this danger.

Use your neighbor's phone or a street fire alarm box. The job of extinguishing the fire should be left to the professionals. Too many unforeseen things can occur when inexperienced people try to extinguish a fire.

BE PREPARED. Perform fire drills regularly. Use them to assure recognition of an alarm signal. For your protection, simulate different circumstances (smoke in hall, in living room, etc.). Then have everyone react to the situation.

Draw a floor plan and show two exits from each room. Frequently, a knotted rope or ladder from a window will serve this purpose. It is important that children be instructed carefully, because they tend to hide in times of crisis.

It is imperative that one meeting place outside the home be established. You should insist that everyone meet there during an alarm. This will eliminate the tragedy of someone reentering the house for a missing member who is actually safe.

If you have children and/or invalids residing in your household, you can help your fire department. Most fire departments have window decals available for use in children's or invalid's bedrooms. Properly **USED**, these decals will quickly identify sleeping quarters of these individuals and show the department where to look first for members of your household.

® Additional information on Household Fire Warning is available at nominal cost from The National Fire Protection Agency, Batterymarch Park, Quincy, MA 02269. Request Standard No. NFPA 72.

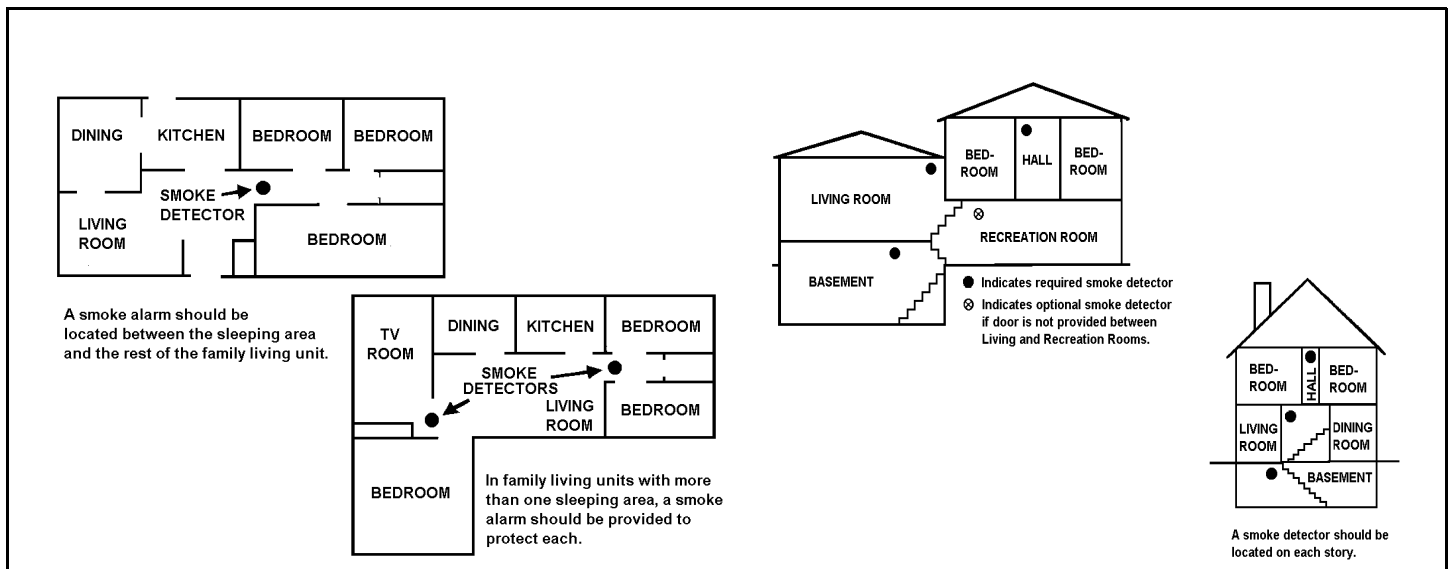

NAPCO LIMITED WARRANTY

NAPCO SECURITY SYSTEMS, INC. (NAPCO) warrants its products to be free from manufacturing defects in materials and workmanship for *thirty-six months* following the date of manufacture. NAPCO will, within said period, at its option, repair or replace any product failing to operate correctly without charge to the original purchaser or user.

This warranty shall not apply to any equipment, or any part thereof, which has been repaired by others, improperly installed, improperly used, abused, altered, damaged, subjected to acts of God, or on which any serial numbers have been altered, defaced or removed. Seller will not be responsible for any dismantling or reinstallation charges.

THERE ARE NO WARRANTIES, EXPRESS OR IMPLIED, WHICH EXTEND BEYOND THE DESCRIPTION ON THE FACE HEREOF. THERE IS NO EXPRESS OR IMPLIED WARRANTY OF MERCHANTABILITY OR A WARRANTY OF FITNESS FOR A PARTICULAR PURPOSE. ADDITIONALLY, THIS WARRANTY IS IN LIEU OF ALL OTHER OBLIGATIONS OR LIABILITIES ON THE PART OF NAPCO.

Any action for breach of warranty, including but not limited to any implied warranty of merchantability, must be brought within the six months following the end of the warranty period. IN NO CASE SHALL NAPCO BE LIABLE TO ANYONE FOR ANY CONSEQUENTIAL OR INCIDENTAL DAMAGES FOR BREACH OF THIS OR ANY OTHER WARRANTY, EXPRESS OR IMPLIED, EVEN IF THE LOSS OR DAMAGE IS CAUSED BY THE SELLER'S OWN NEGLIGENCE OR FAULT.

In case of defect, contact the security professional who installed and maintains your security system. In order to exercise the warranty, the product must be returned by the security professional, shipping costs prepaid and insured to NAPCO. After repair or replacement, NAPCO assumes the cost of returning products under warranty. NAPCO shall have no obligation under this warranty, or otherwise, if the product has been repaired by others, improperly installed, improperly used, abused, altered, damaged, subjected to accident, nuisance, flood, fire or acts of God, or on which any serial numbers have been altered, defaced or removed. NAPCO will not be responsible for any dismantling, reassembly or reinstallation charges.

This warranty contains the entire warranty. It is the sole warranty and any prior agreements or representations, whether oral or written, are either merged herein or are expressly cancelled. NAPCO neither assumes, nor authorizes any other person purporting to

act on its behalf to modify, to change, or to assume for it, any other warranty or liability concerning its products.

In no event shall NAPCO be liable for an amount in excess of NAPCO's original selling price of the product, for any loss or damage, whether direct, indirect, incidental, consequential, or otherwise arising out of any failure of the product. Seller's warranty, as hereinabove set forth, shall not be enlarged, diminished or affected by and no obligation or liability shall arise or grow out of Seller's rendering of technical advice or service in connection with Buyer's order of the goods furnished hereunder.

NAPCO RECOMMENDS THAT THE ENTIRE SYSTEM BE COMPLETELY TESTED WEEKLY.

Warning: Despite frequent testing, and due to, but not limited to, any or all of the following; criminal tampering, electrical or communications disruption, it is possible for the system to fail to perform as expected. NAPCO does not represent that the product/system may not be compromised or circumvented; or that the product or system will prevent any personal injury or property loss by burglary, robbery, fire or otherwise; nor that the product or system will in all cases provide adequate warning or protection. A properly installed and maintained alarm may only reduce risk of burglary, robbery, fire or otherwise but it is not insurance or a guarantee that these events will not occur. CONSEQUENTLY, SELLER SHALL HAVE NO LIABILITY FOR ANY PERSONAL INJURY, PROPERTY DAMAGE, OR OTHER LOSS BASED ON A CLAIM THE PRODUCT FAILED TO GIVE WARNING. Therefore, the installer should in turn advise the consumer to take any and all precautions for his or her safety including, but not limited to, fleeing the premises and calling police or fire department, in order to mitigate the possibilities of harm and/or damage.

NAPCO is not an insurer of either the property or safety of the user's family or employees, and limits its liability for any loss or damage including incidental or consequential damages to NAPCO's original selling price of the product regardless of the cause of such loss or damage.

Some states do not allow limitations on how long an implied warranty lasts or do not allow the exclusion or limitation of incidental or consequential damages, or differentiate in their treatment of limitations of liability for ordinary or gross negligence, so the above limitations or exclusions may not apply to you. This Warranty gives you specific legal rights and you may also have other rights which vary from state to state.